



**Product catalog**

[www.ekopanely.com](http://www.ekopanely.com)





PANELY CZ. S.r.o. 04/2019-DoP-01.03.2019  
3986:2004+A1:2015 38, 58 mm, E, EI, A+

2000



↓TOP↓

PANELY<sup>®</sup>

2000



2019 ↓TOP↓



# How did it start?

In 1997, we discovered the potential of the technical properties of natural building boards made from pressed straw. However, the history of straw board production and use dates back to the middle of the last century, when straw boards were widely used to restore houses destroyed by war in Great Britain. Based on proven technology, we have started the development of more modern technology with the aim of producing a quality construction product with the highest parameters for the requirements of today's construction.

In 1999, we founded the family company EKOPANELY, which was the first company on the European continent to start producing this environmentally friendly and energy-saving material. After more than 20 years of our successful existence, we are constantly working to improve the quality of our production and expand the range of application of our products and solutions. The quality of our products has resulted in the winning of a number of awards. In 2008, the Czech Construction Academy's Golden Award for a construction product and in 2012, the Czech Patron award from the Czech Chamber of Commerce.





Our team is ready to help you with the reconstruction of new building partitions or loft conversions up to the design and construction of your house on a turnkey basis. We are the only company that guarantees the quality of an annual production of more than 100,000 m<sup>2</sup> of our building boards. The process starts with the selection of quality straw, continues with the process of production and inspection of the boards, which can then be used for building a house.



# What is an Ekopanely board?

An Ekopanely board is an ecological diffusion-open building board. It is pressed at high temperature and pressure from cereal straw without the use of binders and covered with recycled cardboard. Ekopanely board is a 100% natural, fully recyclable, solid and diffusion-open building material suitable for permanent installation in buildings.

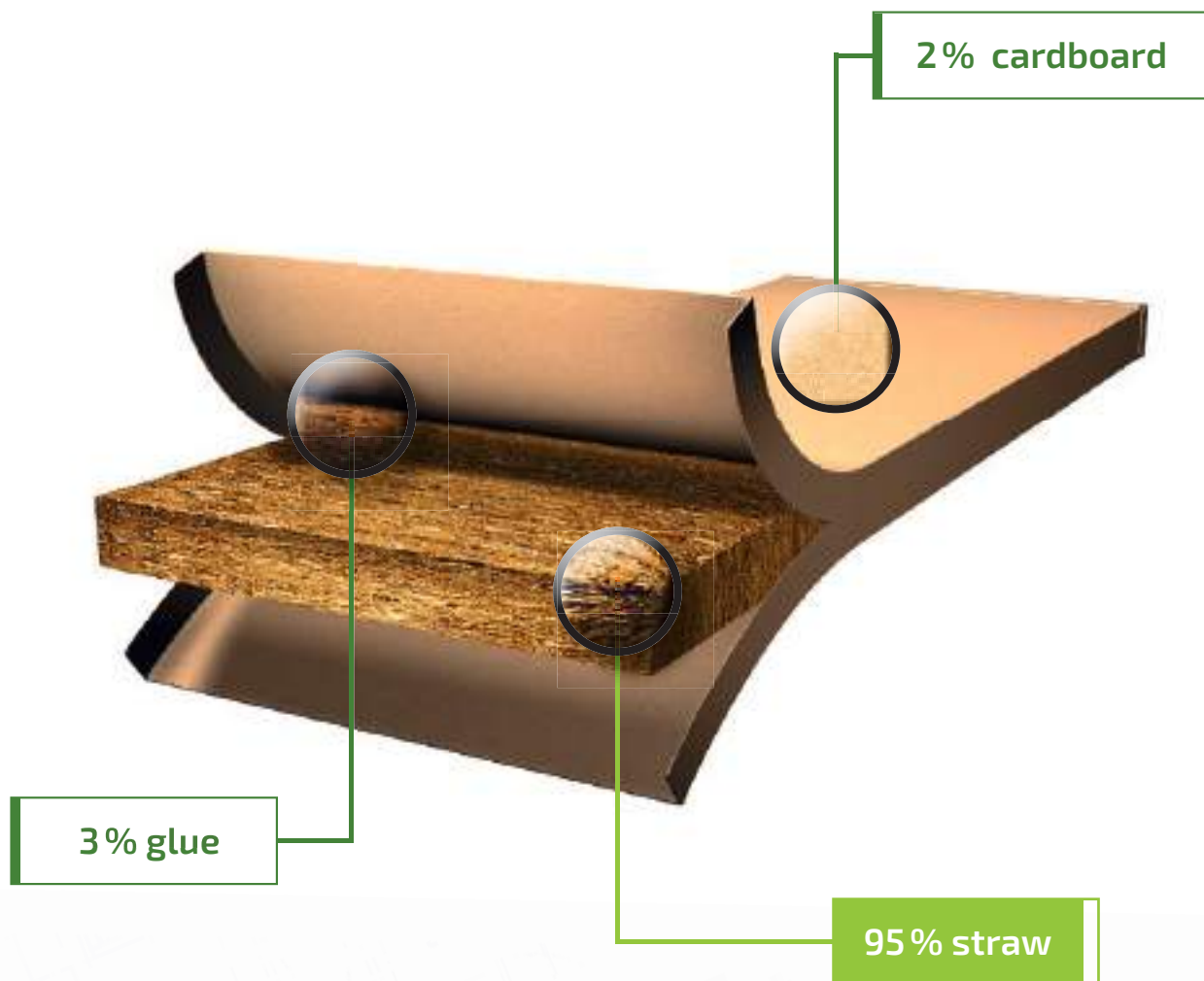





Certified building system



Sound insulating properties



Thermal insulating properties



Heat accumulation



Mechanical resistance and strength



Fire resistance



Fast and simple installation



Affordability



Healthy microclimate, interior humidity stability



Ecological housing

# Advantages of Ekopanely boards



## Certified building system

Demonstrating application parameters is an important step in gaining customer confidence. These are verified by testing in accredited testing laboratories in accordance with valid standards. This especially applies to fire and sound parameters.



## Sound insulating properties

Due to the higher density and fiber core, Ekopanely boards have excellent acoustic properties. Simply put, they do not transmit much vibration to other structures and at the same time they have good absorption properties, i.e. they do not reflect sound (there is no echo). These features can be used, for example, in music recording studios. The density of the straw core, the orientation of the Ekopanely boards fibers and other parameters are behind the excellent sound-insulating properties of the Ekopanely boards. The classic feature of spaces built from Ekopanely boards is the absence of echo.



## Thermal insulating properties

With their insulating capabilities, Ekopanely boards help to overlay thermal bridges in a building over the whole area caused by a wooden load-bearing structure, anchoring or the discontinuous layer of thermal insulation.





## Heat accumulation

The densified compressed straw core gives Ekopanely boards the ability to store heat with the added value of thermal insulation properties. Ekopanely boards buildings are better able to cope with rapid temperature changes and thus save heating costs. They also help prevent overheating in the summer months.

Phase shifts are given for individual system applications, while it is always necessary to assess the entire structure of the construction, not just the selected layer. For example, heat penetrates into a building with a delay in summer, i.e. by the gradual heating of individual layers. Overnight, the wooden building is "cooled" down with air at a lower temperature and keeps the cold until the evening. In winter, on the other hand, the wooden building heats up during the day and keeps the warmth until morning, even if you stop heating in the evening. A rational solution is the application of Ekopanely boards in the creation of a residential attic space due to the frequent overheating of attic spaces in summer. OSB boards or plasterboard do not have such storage capacity.



## Mechanical resistance and strength

Due to the core density and the high pressing pressure used in production, the Ekopanely board has very good mechanical properties. Above all, its puncture resistance is excellent. The partition or suspended ceiling simply cannot be broken through with a hammer or other sharp object.



## Fire resistance

The straw core is compressed under high pressure and therefore contains a minimum amount of air. The minimum amount of air cannot support combustion and creates a self-extinguishing effect. This self-extinguishing effect is one of its distinct advantages. The Ekopanely board does not contain chemicals whose vapors would be flammable and thus promote its combustion.





# Advantages of Ekopanely boards

1  
5  
2

## Affordability

The installation of Ekopanely boards is quick and easy. After training, it can be handled by a skilled craftsman or directly by the investor. This can reduce investment costs. Although the Ekopanely board is an ecological material, it is still affordable for ordinary customers. When comparing the parameters of similar products with the Ekopanely board, you will find out that the Ekopanely board is the right choice! The ratio of quality, parameters, cost savings and cost is really friendly.



## Healthy microclimate, interior humidity stability

Due to the fibrous nature of straw, the materials made from it have low thermal conductivity and are permeable to water vapor. A favorable feature of Ekopanely boards is that they absorb excess moisture into the inner porous structure of the straw fibers when the air humidity is increased and, when it is lowered, gradually releases it into the environment. This mechanism positively affects the indoor microclimate, especially in winter.



## Ecological housing

The Ekopanely board core is pressed from cereal straw at high pressure and temperature without added binders and impregnations. The straw core is covered with recycled paperboard. This adhesive complies with the strictest hygienic standards and is applied in a thin layer. Both straw and paper are organic materials that can easily be recycled once the building has reached the end of its life. Ekopanely board is classified as an organic product. The Ekopanely boards are delivered to the customer in the required length, thus minimizing waste and saving costs. By using Ekopanely boards in house constructions you will ensure healthy living for you and your family. Ekopanely boards are rated A+ (VOC) and therefore free of any inorganic vapors.





## E60 Ekopanely board

Description	Value	Unit	Legal regulation
dimensions (thickness, width, length)	60 × 1200 × 1200 – 3200	mm	
average area weight	22	kg/m <sup>2</sup>	
volume average weight	379	kg/m <sup>3</sup>	
thermal conductivity coefficient: $\lambda$	0,099	W/(m.K)	ČSN EN 13986, EN 12664, EN 10456
diffusion resistance coefficient: $\mu$	9,7		ČSN EN 13986, EN ISO 12572 B (23 °C, 0/85 % relative humidity)
reaction to fire: category	E		ČSN EN 13986, EN 13501-1
determination of free volatile organic compounds (TVOC)	A+		ČSN EN ISO 16000-10

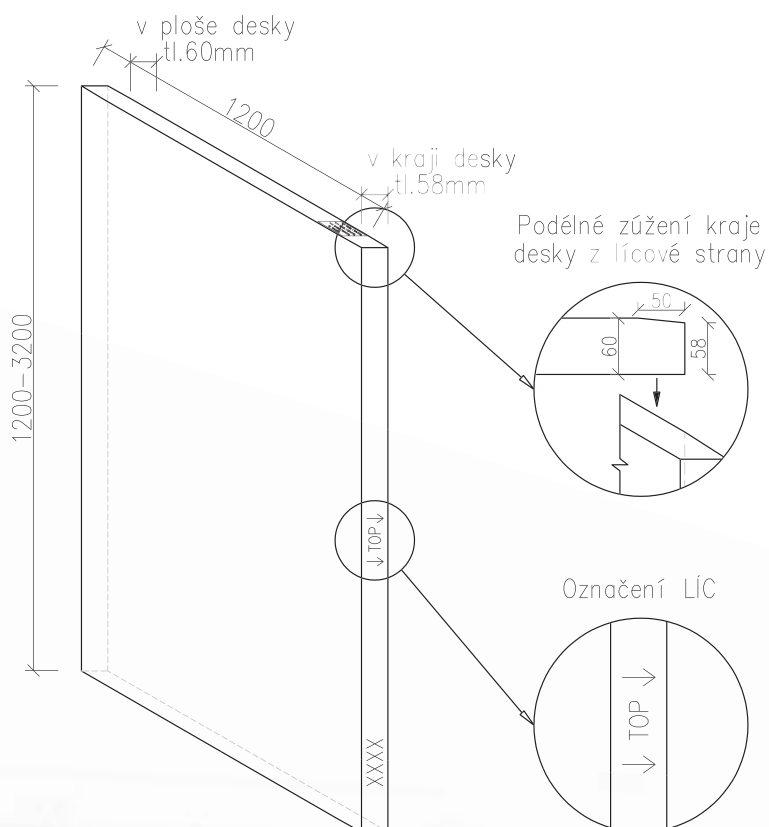

Skladování max. 3x balík (20ks)

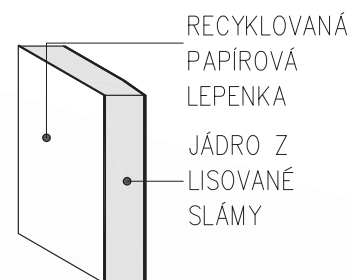
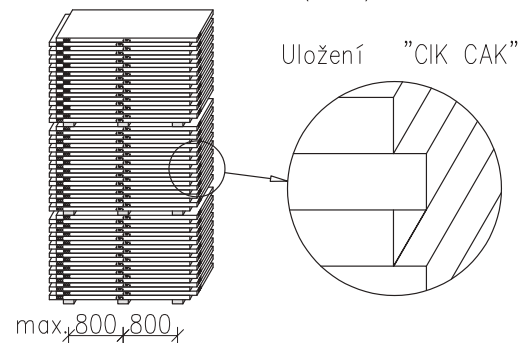



# Technical parameters

## E40 Ekopanely board

Description	Value	Unit	Legal regulation
dimensions (thickness, width, length)	40 × 800 × 1200 – 3200	mm	
average area weight	17	kg/m <sup>2</sup>	
volume average weight	379	kg/m <sup>3</sup>	
thermal conductivity coefficient: $\lambda$	0,099	W/(m.K)	ČSN EN 13986, EN 12664, EN 10456
diffusion resistance coefficient: $\mu$	9,7		ČSN EN 13986, EN ISO 12572 B (23 °C, 0/85 % relative humidity)
reaction to fire: category	E		ČSN EN 13986, EN 13501-1
determination of free volatile organic compounds (TVOC)	A+		ČSN EN ISO 16000-10

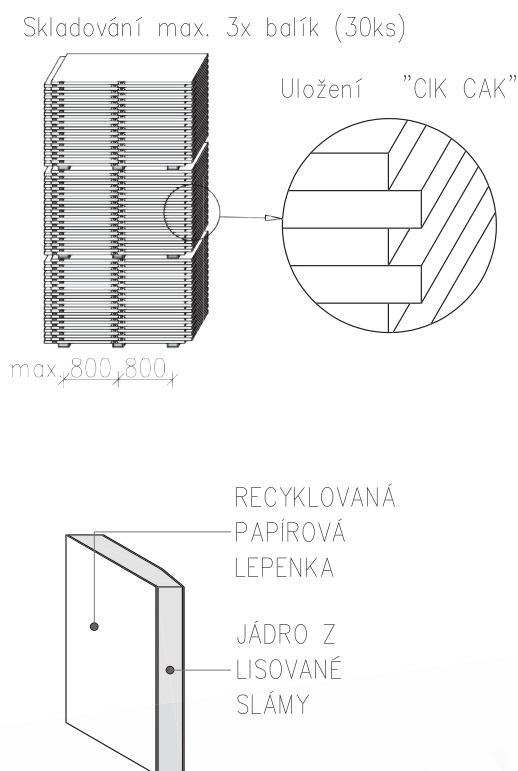
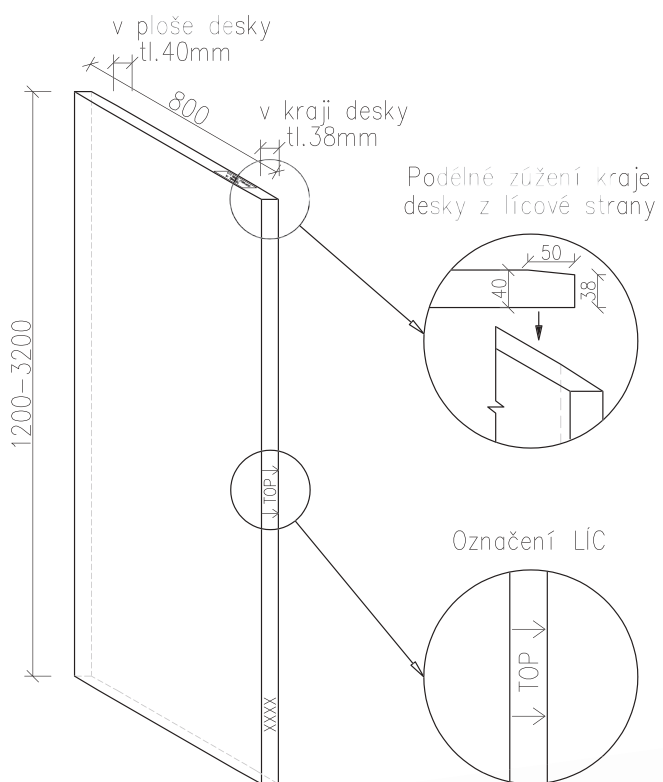

# Application - partitions



## E2 M partition, thk. 80 + X mm

**RECOMMENDED**

Installation partition for non-load-bearing purposes

**Recommended use:**

- partitions with technical distributions and installations
- partitions with a higher need for soundproofing (kids room, bathroom, bedroom,...)

**Parameters:**

- max partition height 3200 mm for standard application
- 2 layers of E40 including sheet metal grating and acoustic insulation
- important ordering of height of Ekopanel boards according to height of custom-made partition (1200 – 3200 mm)
- soundproofing 51 dB (X = 50 mm)
- fire resistance EI 60 DP3



## E2 W partition, thk. 80 + X mm

Installation partition for non-load-bearing purposes

**Recommended use:**

- partitions with technical distributions and installations
- partitions dividing any room in a building (corridor, kitchen, living room, bathroom, bedroom, ...)

**Parameters:**

- max partition height 3200 mm for standard application
- 2 E40 layers on wooden construction
- the gap between the Ekopanel boards is always supported by a wooden wall upright
- selection of X = 40/60 mm according to the selected wooden profile
- ordering of the Ekopanel board height according to the size of the custom-made partition (1200 – 3200 mm)



## E2 N partition, thk. 240 mm

Internal supporting partition

**Recommended use:**

- partitions for supporting purposes and building reinforcement

**Parameters:**

- max partition height according to the design of the supporting structure
- E60, KVH prism including acoustic insulation, E60
- important ordering of the length of Ekopanel boards according to height of the custom-made partition (1200 – 3200 mm)
- fire resistance REI 45 DP3



## E1 partition, thk. 60 mm

Self-supporting simple partition for non-load-bearing purposes

**Recommended use:**

- lightweight partitions and screens
- bathroom (optical toilet partition)
- kitchen (drawing the wall to the kitchen unit)
- dividing a dressing room
- dividing the space below the stairs

**Parameters:**

- max partition height 2800 mm
- usage only 1 pc E60 vertically
- important ordering of length of Ekopanel boards according to height of custom-made partition (1200 – 2800 mm)
- fire resistance EI 30 DP3
- soundproofing 33 dB



# Application - suspended ceilings

## EK01 slope – E40, thk. 64 mm

**RECOMMENDED**



### Simple inner covering of slopes

#### Recommended use:

- slope ceilings of ceiling and roof structures
- attic build-ins

#### Parameters:

- 1 layer of E40, wooden grating, thermal insulation
- heat transfer coefficient  $U = 0.145 \text{ W/m}^2\cdot\text{K}$  (insulant  $\lambda=0.039 \text{ W/m}\cdot\text{K}$ , 240 mm)
- phase shift up to 8 hours
- fire resistance REI 30 DP3

## EK01 slope – E60, thk. 84 mm



### Simple inner covering of slopes

#### Recommended use:

- slope ceilings of ceiling and roof structures
- attic build-ins

#### Parameters:

- 1 layer of E60, wooden grating, thermal insulation
- heat transfer coefficient  $U = 0.141 \text{ W/m}^2\cdot\text{K}$  (insulant  $\lambda=0.039 \text{ W/m}\cdot\text{K}$ , 240 mm)
- phase shift up to 9 hours
- fire resistance REI 45 DP3

## EK01 ceiling – E40, thk. 64 mm

**RECOMMENDED**



### Simple inner covering of ceilings

#### Recommended use:

- horizontal ceilings of ceiling and roof structures

#### Parameters:

- 1 layer of E40, wooden grating, thermal insulation
- heat transfer coefficient  $U = 0.144 \text{ W/m}^2\cdot\text{K}$  (insulant  $\lambda=0.039 \text{ W/m}\cdot\text{K}$ , 240 mm)
- phase shift up to 8 hours
- fire resistance REI 30 DP3

## EK01 ceiling – E60, thk. 84 mm



### Simple inner covering of ceilings

#### Recommended use:

- horizontal ceilings of ceiling and roof structures

#### Parameters:

- 1 layer of E60, wooden grating, thermal insulation
- heat transfer coefficient  $U = 0.140 \text{ W/m}^2\cdot\text{K}$  (insulant  $\lambda=0.039 \text{ W/m}\cdot\text{K}$ , 240 mm)
- phase shift up to 9 hours
- fire resistance REI 45 DP3

## Application - existing wall cladding | sandwich constructions

### EK02 perimeter wall, thk. 360 mm



Supporting perimeter structure including covering from Ekopanel boards

**Recommended use:**

- vertical perimeter structures of low-cost houses

**Parameters:**

- max wall height according to the design of the supporting structure
- fibreboard, KVH prism including thermal insulation, E60, wooden grating, E40
- heat transfer coefficient  $U = 0.153 \text{ W/m}^2\cdot\text{K}$
- fire resistance REI 120 DP3

### EK01 inner cladding – E40



Simple inner covering of existing walls

**Recommended use:**

- vertical cladding of masonry and wooden walls
- attic build-ins, timbered houses, log cabins, half-timbered constructions

**Parameters:**

- 1 layer E40 on wooden construction grating
- increases insulation parameters of existing wall
- improves the acoustic parameters

### EK01 inner cladding – E60



Simple inner covering of existing walls

**Recommended use:**

- vertical cladding of masonry wall and wooden structures
- attic build-ins, timbered houses, log cabins, half-timbered constructions

**Parameters:**

- 1 layer E60 on wooden grating
- increases the insulation parameters of the existing wall
- improves the acoustic parameters



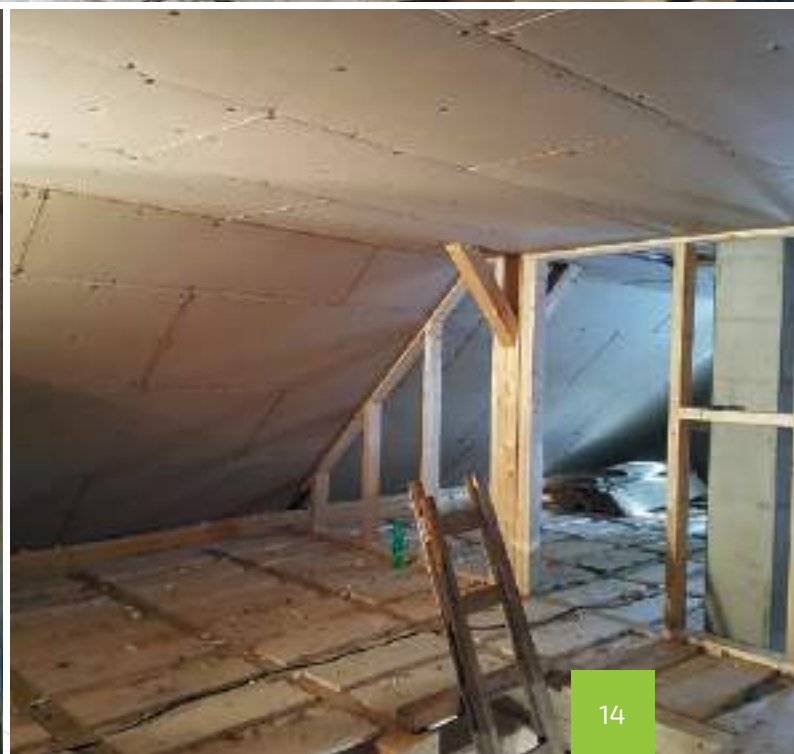





### Holiday cottage in Prague

Combination of wooden frame and frame construction. Some parts are prefabricated on CNC machines due to granted details and static requirements. The cottage has a fully glazed gable in which part is an open gallery. The whole building is lined with a final layer of wooden siding from Siberian larch.





# Reference



## Wooden building in Vysočina (Highlands Region)

The design of the new building was created in an architectural studio so that it perfectly blends in with the surrounding landscape of the Žďár forests, which are almost part of the plot.











### Family house in Mnichovice near Prague

In September 2015, the construction of a one-storey family house with a residential attic with the Ekopanely boards system was started in Mnichovice near Prague. EKOPANELY SERVIS s.r.o. supplied construction work up to the construction phase before completion according to their own documentation. The built-up area of the house is 93.3 m<sup>2</sup>. The investor realized the foundations on his own. The project is based on an architectural study of a gable roofed family house located near the forest. In the main living room, there will be large glazed areas and an open gallery up to the ridge and a wooden ventilated facade will be installed from outside.





- Design, manufacture and construction
- More than 600 realizations in CZ
- Low-energy and passive wooden buildings
- Production of Ekopanely boards since 1999
- More than 20 years of experience
- Exports to the whole world
- Unique production in Europe
- 2 production lines
- Variability of dimensions

## Advantages of buildings in the Ekopanely boards system

- |                              |                      |                               |                                   |
|------------------------------|----------------------|-------------------------------|-----------------------------------|
| ▪ Heat accumulation          | ▪ Insulating ability | ▪ Self-help                   | ▪ 100% organic product            |
| ▪ Acoustic ability           | ▪ Thermal stability  | ▪ Simple installation         | ▪ Natural climate in the building |
| ▪ Diffusion-openness         | ▪ Energy efficiency  | ▪ Speed of dry construction   | ▪ Medical harmlessness            |
| ▪ High mechanical resistance | ▪ Fire resistance    | ▪ Custom formatting of boards | ▪ Recyclability                   |

## Our services

- Standard and individual buildings
- Project works
- Production documentation
- Custom made production of Ekopanely boards
- Professional training in the Ekopanely boards system
- Implementation of wooden buildings
- Implementation of residential attics
- Implementation of reconstruction and extensions
- Technical support
- Construction supervision

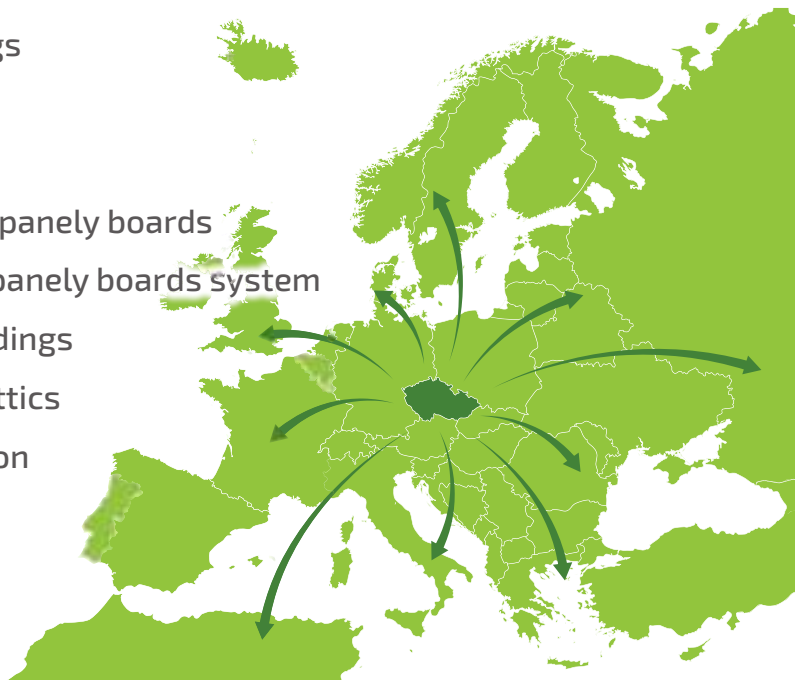

QR CARD



### MORE INFORMATION AT:

tel: +420 466 972 421, email: [info@ekopanely.com](mailto:info@ekopanely.com)  
[www.ekopanely.com](http://www.ekopanely.com)

**EKOPANELY SERVIS s.r.o.**

Jedousov 64, 535 01 Přelouč, Czech Republic